



Black & Decker

Workmate™

ALL-PURPOSE WORK CENTRE AND VISE INSTRUCTION MANUAL

type 6 84722 = Nov. 21, 1978 manufactured

79-001

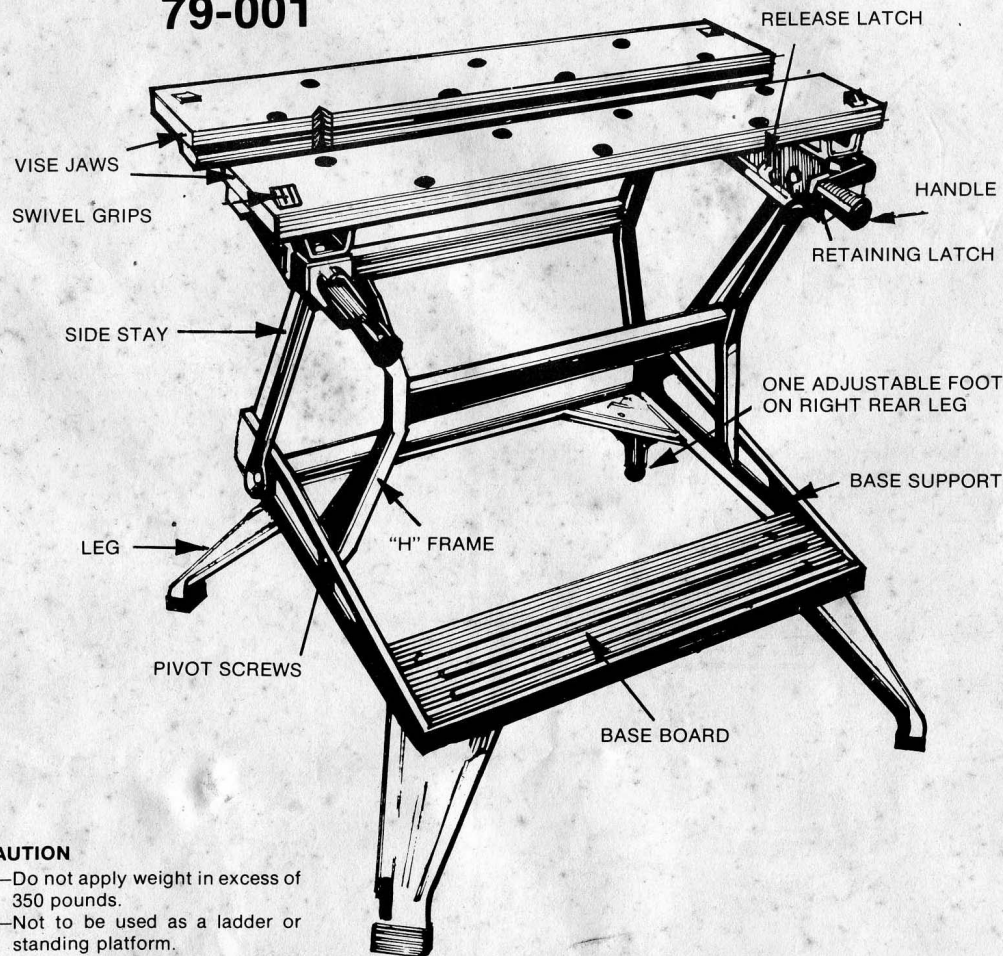

Your new Workmate is a quality piece of equipment that has been carefully designed and manufactured to provide years of dependable service.

This instruction manual will familiarize you with the Workmate. It lists important facts and features which describe the Workmate's construction and basic operating techniques. Set up instructions and various usage situations are also provided.

Read this manual carefully. Only by being totally aware of what the Workmate can do will you be able to put it to the numerous tasks it is capable of performing.

CAUTION

- 1.—Do not apply weight in excess of 350 pounds.
- 2.—Not to be used as a ladder or standing platform.

SAFETY RULES:

1. Do not load with more than 350 lbs.
2. Do not apply an unbalanced load which could cause the Workmate to tip.
3. Do not use lower platform as a step when Workmate is in workbench position.
4. Do not use Workmate as a stepladder or standing platform.
5. Do not store Workmate outdoors or in damp condition.
6. Avoid applying excessive force when clamping in only the lower half of the vise jaws or when using the swivel grips.
7. Be sure that table locks in sawhorse position and that legs lock in workbench position.
8. When using a power tool with the Workmate, follow the safety rules in the tool's instruction manual.
9. Wear safety glasses when using power tools.
10. See "Using Power Equipment" (page 3) for correct method of securing power tools in Workmate. Never mount power tools directly in vise; pressure may damage tools.
11. An even pressure of jaws on work piece is essential. Tighten both jaw handles uniformly.

MAINTENANCE TIPS:

1. Pivot screws are of low friction design. No lubrication is necessary.
2. If binding of vise jaw occurs, cleaning of pivot nut and vise screw may be required.
3. Pivot screws should be checked for tightness.

SETTING UP THE WORKMATE

The Workmate sets up easily into two working heights: the lower "sawhorse" height or the upper "workbench" height. Choose the position best suited to your particular job. In each case, the Workmate provides a rigid work surface.

1. Place the Workmate on the floor as illustrated. Press down on the top of rear vise jaw to seat unit. Then press the two release latches located on either side (as shown) and lift the unit until it locks into position.

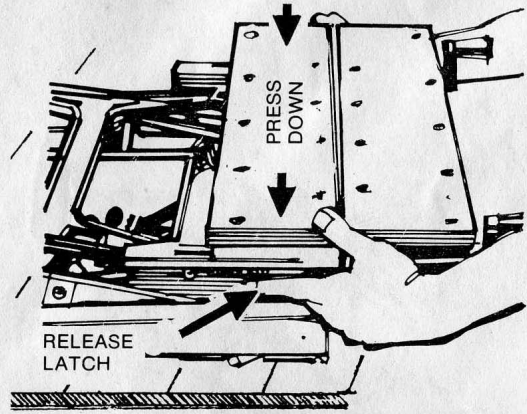

2. This is the lower "Sawhorse" height, measuring 23-1/4" high. Be sure the WORKMATE locks into position.

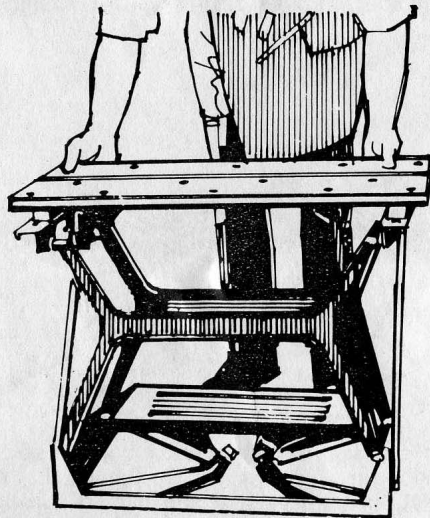

3. To raise the WORKMATE to its full "workbench" height of 31-3/8", extend the 4 base legs as shown.

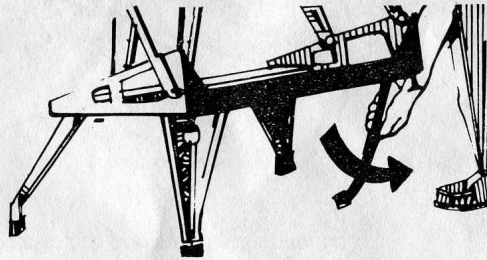

4. Always make sure that each leg locks into its extended position. This will ensure the use of the WORKMATE at this upper working height is secure.

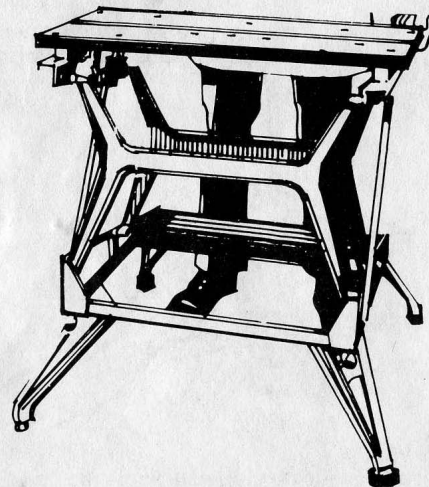

5. To maintain a rigid and balanced WORKMATE in the "workbench" position adjust the adjustable screw foot. Adjustable foot is located on the right rear leg.

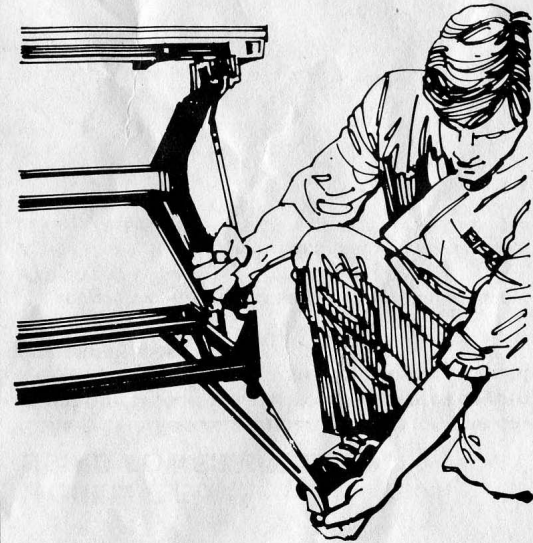

6. The vise handles (packaged separately) are assembled by pushing them into the handle arms until they click into position. This is a permanent connection. Once they have 'clicked' they are locked into position and are ready to use.

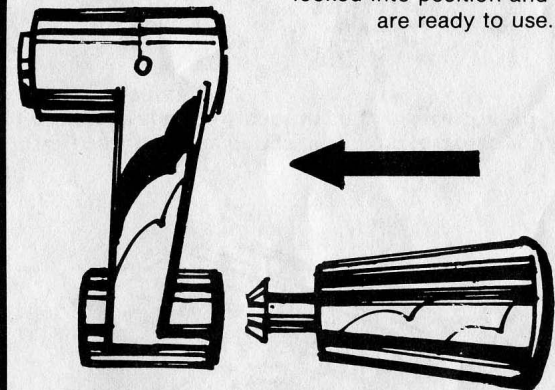

WORKING WITH YOUR WORKMATE

The Workmate is a vise, a sawhorse and an ideal bench. Its basic design and special features help you to perform a complete range of workshop tasks from the simplest to the most complicated.

The heart of the Workmate is in the action of the two parallel vise jaws.

The two vise handles adjust the jaws to a maximum 5-1/4" jaw opening. Because each handle works independently, the opening can be tapered from 0" to 5-1/4" maximum.

Use of the swivel grips in the appropriate vise holes extend the vise capacity of the Workmate to a 12" parallel or 24" diagonal grip.

Note: From illustration 4 to 13. The user's hands are free to hold the tools properly.

1. Adjusting the vise jaws with the vise handles.

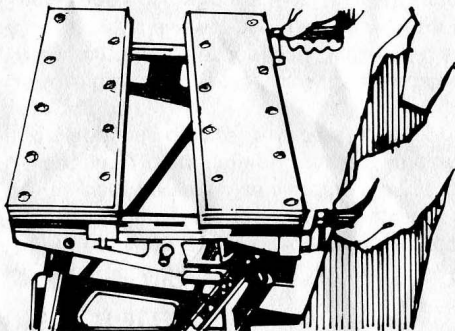

2. Tapering the vise opening using the independent vise handles.

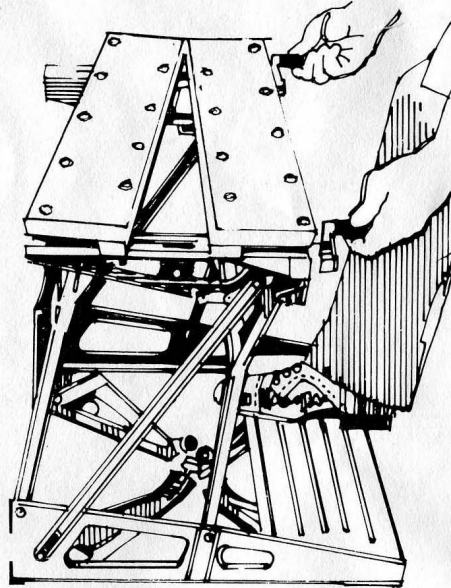

3. Using the swivel grips to extend the vise capacity.

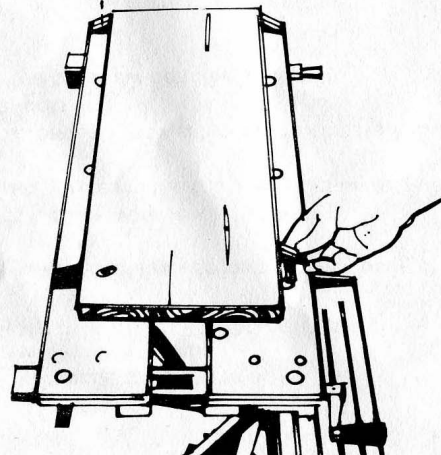
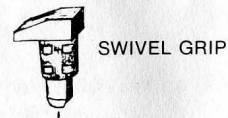

SAWING In its lower position, the Workmate is an ideal sawhorse.

4. For holding material securely.

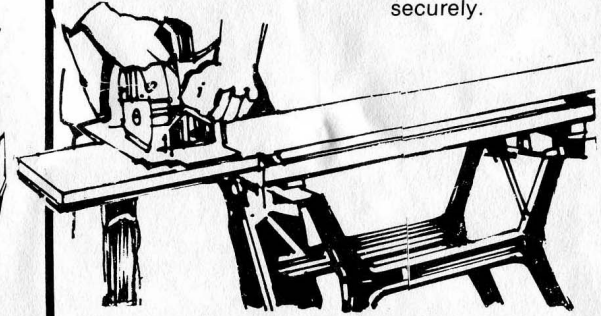

5. Gripping hard-to-hold objects while sawing.

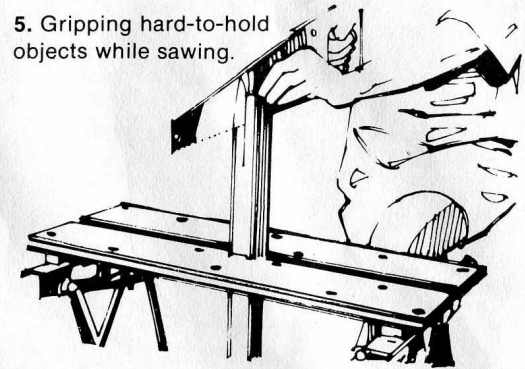

6. Holding a mitre box for more accurate angle cuts. Note: For added rigidity, exert your body weight on the Workmate's base board when sawing or performing other tasks.

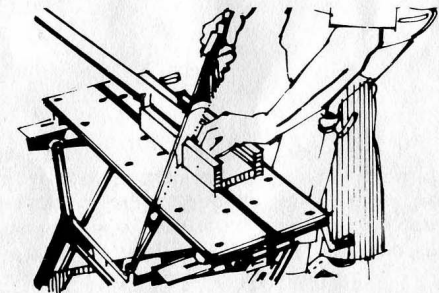

POWER TOOL MOUNTING BOARD

1. Attachments such as the Black & Decker Vertical Drill Stand, the Horizontal Drill Stand may be screwed down to a suitable sized piece of plywood, to the underside of which is attached a block.

SUGGESTED SIZES

A—Mounting Board 12" x 12" x 3/8".

B—Vise Block 2" x 4" x 6".

C—Retaining Board 3" x 3" x 1/4".

D—Bolt 5"

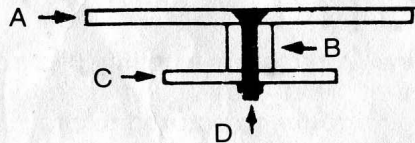

2. The block on the underside of the board is held in the jaws of the Workmate. The power unit is secure for use.

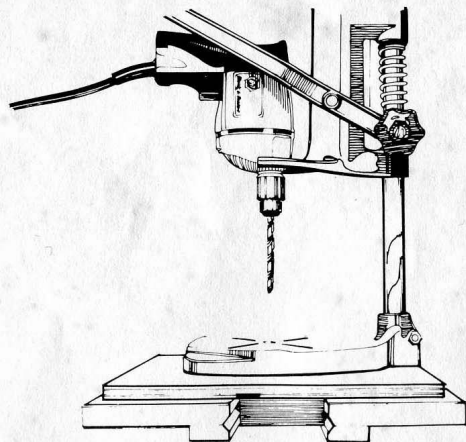

3. Set at the "workbench" height, the Workmate is a perfect mount for cleaning rusty tools and equipment.

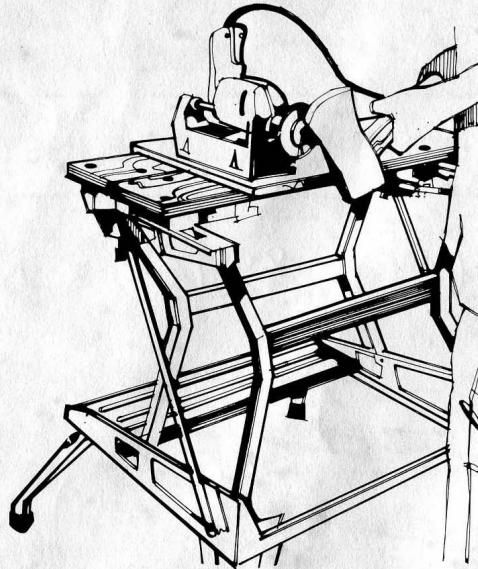

4. Your power drill and drill press can go along with you on any job—across town or into the next room.

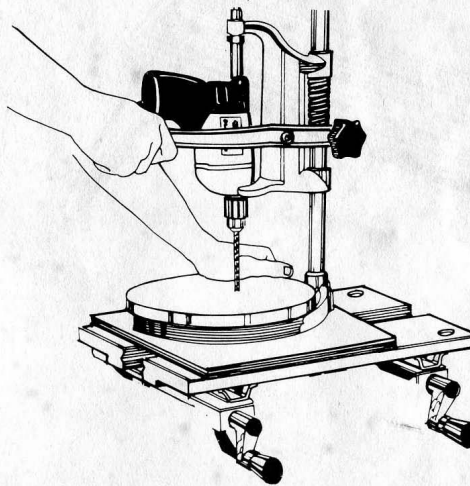

5. You'll want to use all of your power accessories more often. Take buffing—it's easier and more convenient with the Workmate.

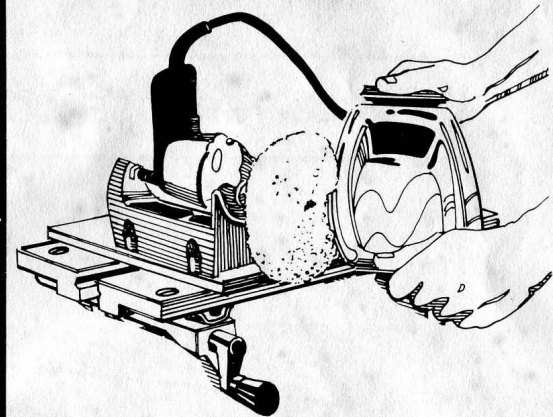

6. Add power equipment you never thought you had room for—grinding is secure with the Workmate as your workbench.

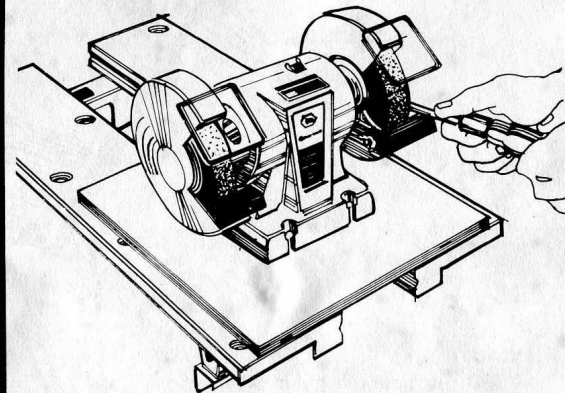

7. Sawing tubular pieces is easy when they are held horizontally in the specially designed V-grooves running along the face of the vise jaws.

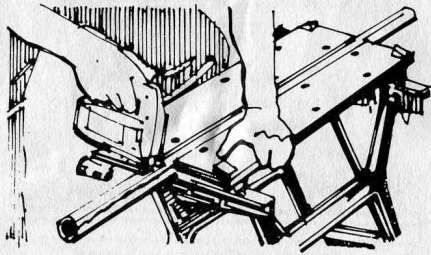

8. Similarly, vertical V-grooves in the face of the vise jaws permit rigid vertical grasping of tubular objects.

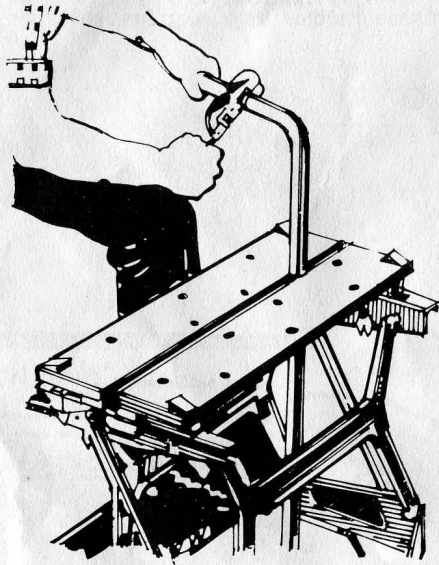

PLANING, SANDING, ROUTING
You can do a better job when the item you are working on is held steady and secure.

9. Holds your stock in perfect height and position.

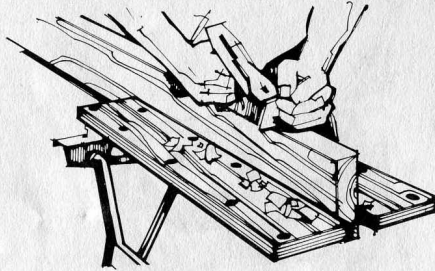

10. Strength and stability to handle the largest and most awkward sizes and shapes.

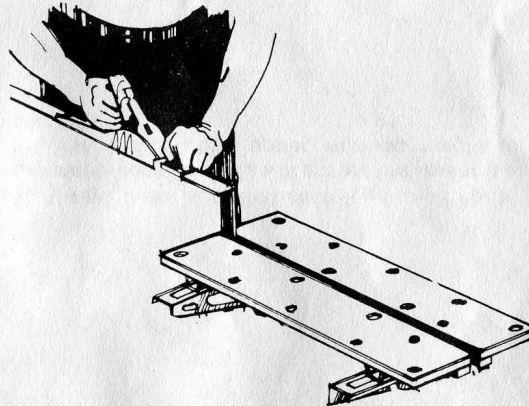

11. Power sand the most irregular shapes and use exactly the pressure that's needed.

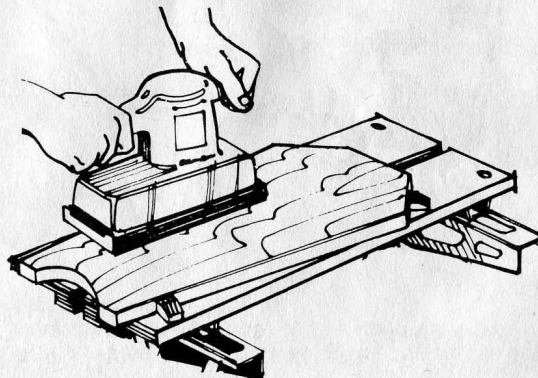

12. Special tasks won't mean special problems anymore. Routing can be easy and the results more professional.

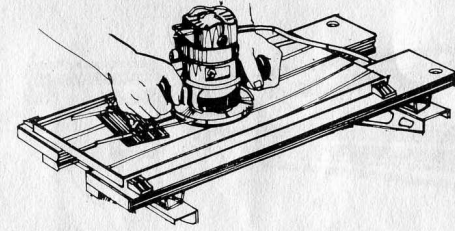

13. The Workmate brings the job up to where you can reach and see it, conveniently, even with hard-to-hold items.

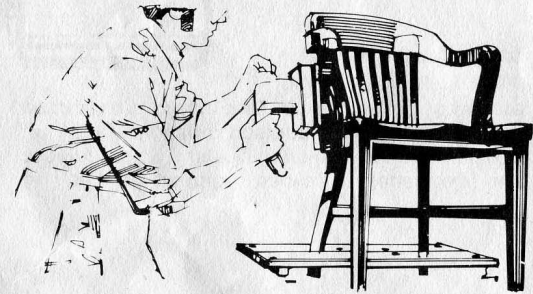

WORKMATE: USING POWER EQUIPMENT

Construct individual mounting blocks for your different power tools to save workbench area in your workshop while making your power equipment completely portable.

CAUTION:

1. Securely mount tool accessories to mounting board with screws or bolts.
2. For safety, it is recommended that you always wear safety glasses when using electrical tools with the Workmate.

WORKMATE HOLDING IRREGULAR SHAPES

Using the swivel grips in the appropriate holes and the independent action of the vise handle, the Workmate can secure the most irregular shapes. Lets you grip objects that used to be impossible to hold.

Rotate swivel grip to accept irregular shape.
Outside swivel grips extend vise capacity for a 24" diagonal grip.

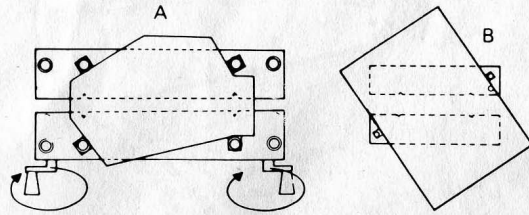

1. When the project calls for extra work space, you can shape up the perfect work table by attaching "block" to the underside of a sheet of plywood. Makes an extra long table surface for any work or play occasion. Care should be taken to centre plywood.

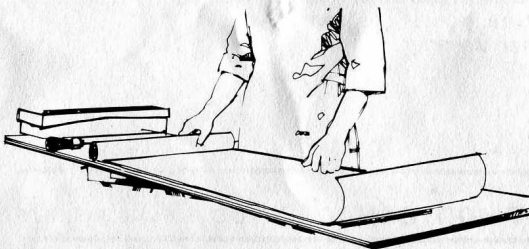

GENERAL PURPOSE TABLE PASTING/ GARDEN SUGGESTED SIZES

2' x 6' Plywood by 1/4"
2" x 4" Stud x 30" long
4 bolts 5" long

CAUTION:

1. Do not use nails or screws, use bolts.
2. Centre pasting board over table working surface.

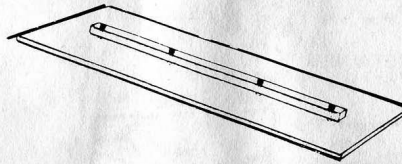

2. Got a bike that needs attention? The Workmate can make the job easier by giving you an extra pair of hands when you really need them.

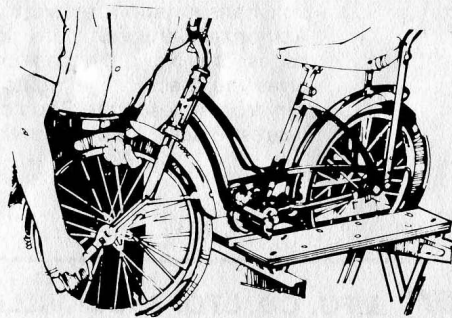

3. The job gets done right the first time, and with less frustration, when the swivel grips get a hold on the problem.

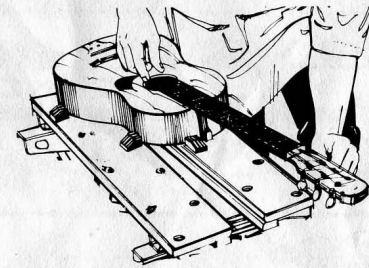

4. It's hard to find a shape that can't be held secure, and the object is always at the proper height to work on.

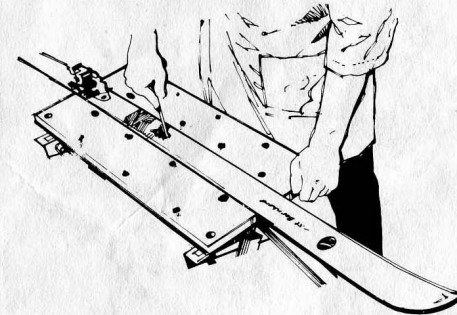

5. Because each end of the vise jaws work independently of each other, it's possible to grasp tapered objects.

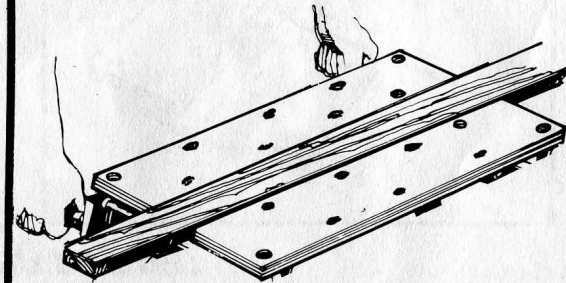

B&D Black & Decker

Workmate™ ACCESSORIES

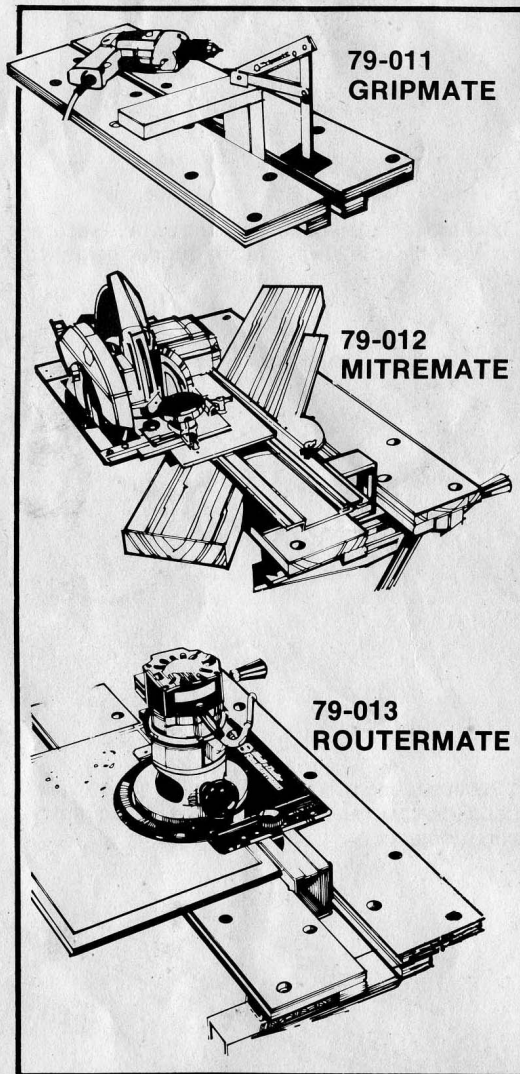

HOW TO STORE YOUR WORKMATE:

1. Store swivel grips upside down in table top until next application. 2. Fold in all four legs and clamp in locked mode. 3. Place one foot on platform. 4. Using index fingers, simultaneously pull both retaining latches toward you. 5. Pull unit straight up until latches release. 6. Close unit and clamp in locked mode. 7. You can now store your Workmate conveniently in minimum space.

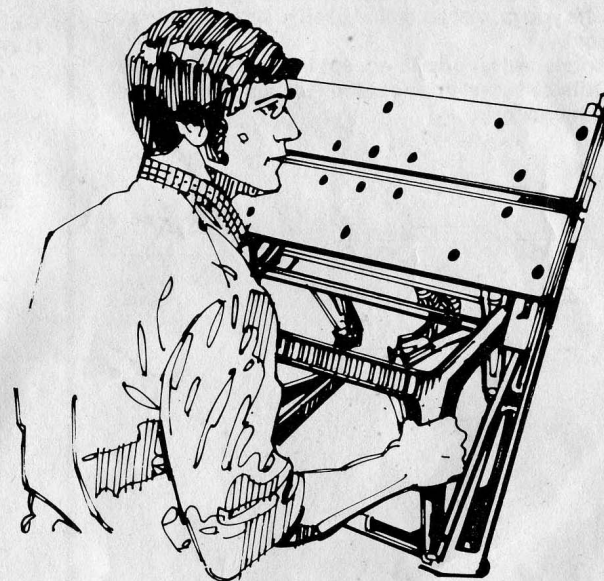
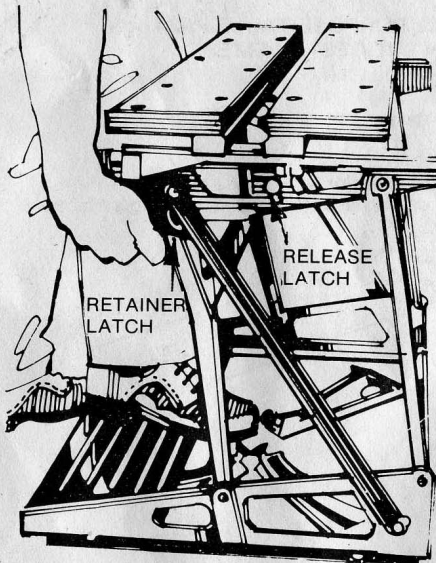

HOME USE WARRANTY (A FULL ONE YEAR WARRANTY)

Black & Decker warrants this product for one year. We will repair without charge, any defects due to faulty material or workmanship or at our option replace the product free. Please return the complete unit, transportation prepaid, to any Black & Decker Service Center or Authorized Service Station listed under "Tools Electric" in the yellow pages. This warranty does not apply to accessories. This warranty gives you specific legal rights and you may have other rights which vary from state to state. Should you have any questions, contact your nearest Black & Decker Service Center Manager.